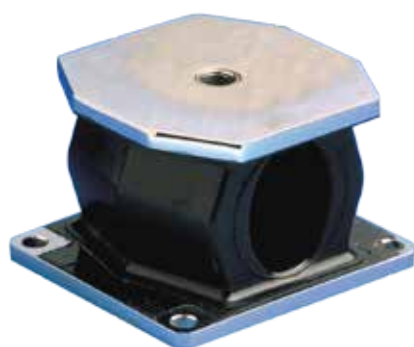

E1C2321**E1T2105****SPECIAL PACKAGING**Natural frequency : (1)
10 to 25 Hz

DESCRIPTION

The special packing dampers have a flexible elastomer element designed for various applications, bonded to two steel mounting plates.

APPLICATIONS

These multi-directional dampers allow considerable deflection to protect equipment transported in containers against drops and transport shocks (missiles, aeronautical equipment).

These dampers are also suitable for suspending equipment to be protected against shocks and vibrations caused by explosions or earthquakes.

1) the indicated natural frequency, are valid for the maxi loads of the ranges of use quoted in the paragraph : TECHNICAL CHARACTERISTICS.

E1C2321

DIMENSIONS

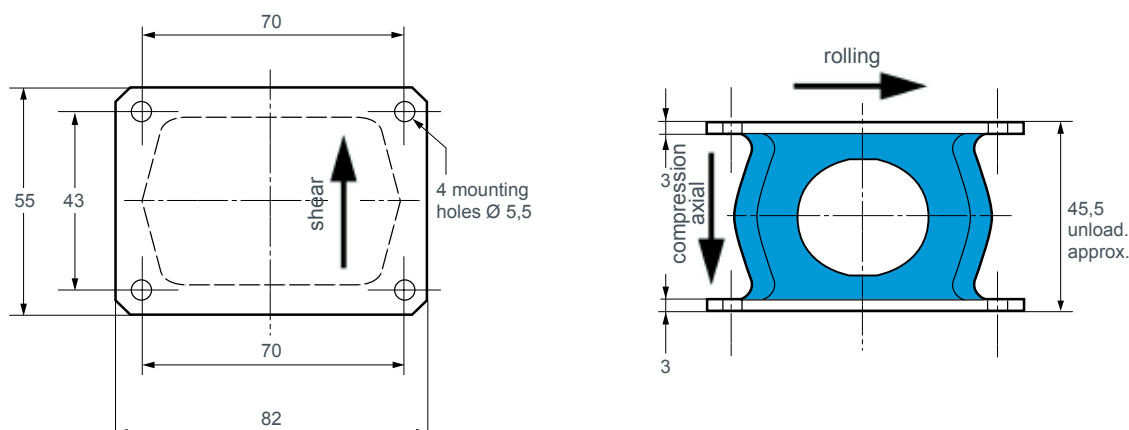

OPERATING CHARACTERISTICS

Natural frequency :
 • axial : 10 to 25 Hz;
 • radial : 10 to 25 Hz.

Maximum permitted excitation at natural frequency of suspension : ± 1.6 mm.
 Maximum travel available for shocks : - axial : 15 mm;
 - radial : 40 mm.

Operating temperature : see table.
 Weight : 0.3 kg.

Reference	Axial static load (daN)	Damping	Resistance to oils and hydrocarbons	Resistance to fatigue	Operating temperature	Material (1)
E1C2321S01	1-10	***	*	*	- 54 to + 150 °C	SIL 33 Sh
E1C2321S02	2-20					SIL 55 Sh
E1C2321-01	2-20	*	**	***	- 30 to + 100 °C	CR 60 Sh
E1C2321-02	5-50					CR 70 Sh
E1C2321-03	10-100					CR 75 Sh
E1C2321-21	2-20	***	*	***	- 40 to + 90 °C	BR 60 Sh
E1C2321-22	5-50					BR 70 Sh
E1C2321-23	10-100					BR 80 Sh

(1) SIL : Silicone; CR : Chloroprene-Rubber; BR : Butadiene-Rubber.

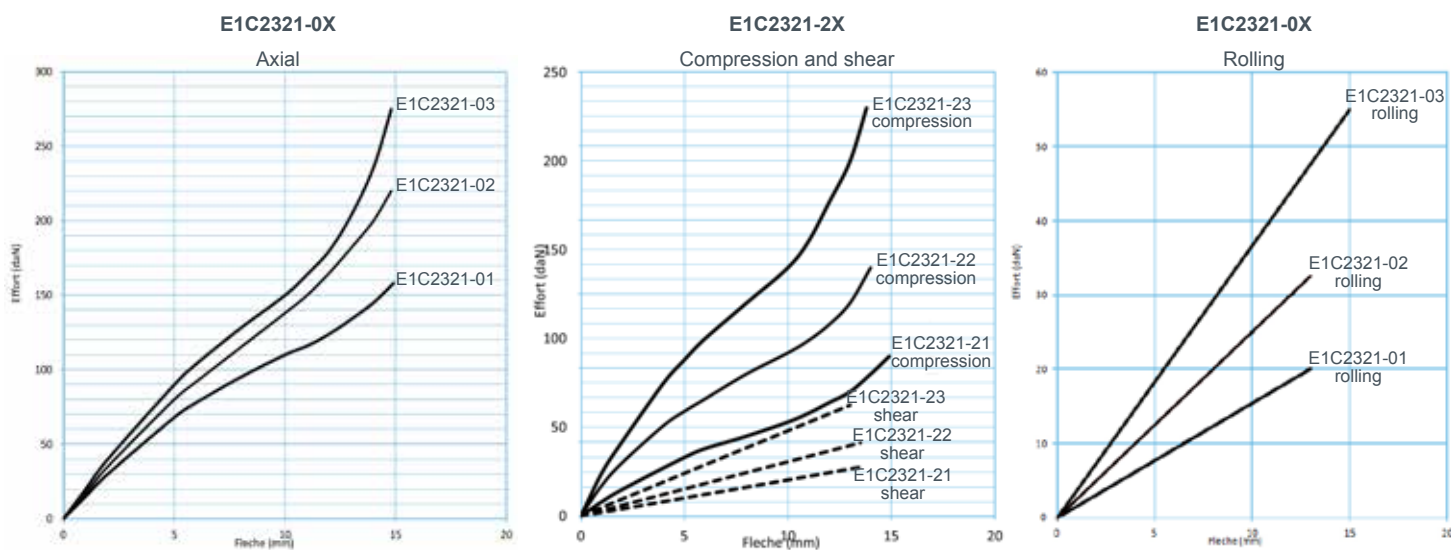

E1C2105

DIMENSIONS

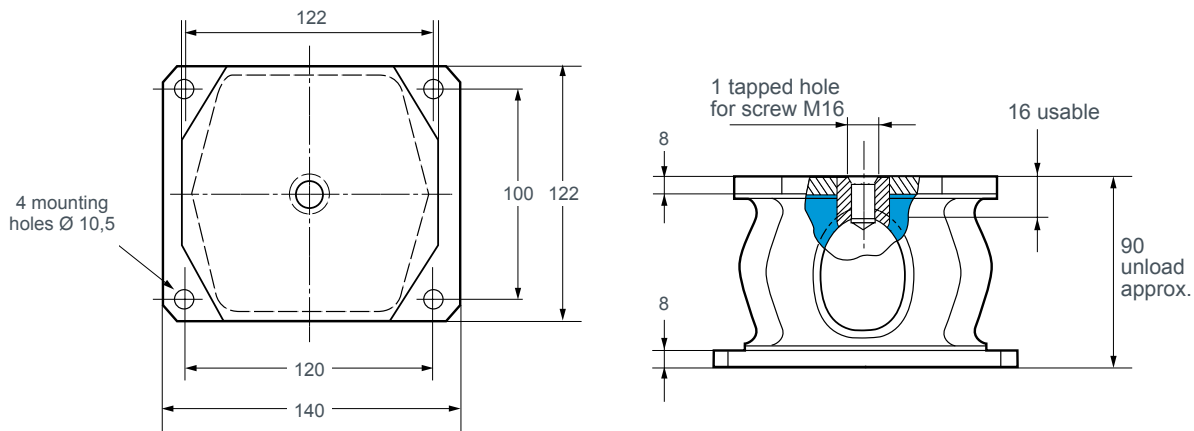

OPERATING CHARACTERISTICS

Natural frequency :

- axial : 10 to 25 Hz;
- radial : 10 to 25 Hz.

Maximum permitted excitation at natural frequency of suspension : ± 1.6 mm.

Maximum travel available for shocks : - axial 40 mm;
- radial 75 mm.

Operating temperature : see table.

Weight : 2.6 kg.

Reference	Axial static load (daN)	Damping	Resistance to oils and hydrocarbons	Resistance to fatigue	Operating temperature
E1T2105S01 E1T2105S02	2-20 4-40	***	*	*	- 54 to + 150 °C
E1T2105-41 E1T2105-42 E1T2105-43	10-100 20-200 40-400	*	***	**	- 25 to + 90 °C
E1T2105-21 E1T2105-22 E1T2105-23	10-100 20-200 50-400	***	*	***	- 40 to + 90 °C